

# Wish Boxes

Great for special occasions and gifts, these thought-filled boxes are created by bringing together two art forms: Calligraphy, which means “beautiful writing” and Origami, which translates as “folded paper”.

**Grade Levels** 3-8

*Note: instructions and materials based on a class of 25. Adjust as needed.*



## Process

1. Use the newsprint to practice drawing different words using cursive, script or natural, flowing letters. Choose words that have significance: “Love”, “Mom”, “Joy”, etc. Repeat the words over and over. Keep in mind that the words will wrap with the box shape, so there will be sections that are unreadable. It is the design created by the colors and shapes of the words that will make the box beautiful. It is important to repeat the same word over and over.
2. After practicing the handwriting on the plain paper, students may begin writing on the tag board. Write directly, don't sketch out in pencil first. Just let the handwriting flow, relax and have fun. Mistakes will be hidden when the box is folded. Write on both squares, on both sides.
3. Make a box, following the instructions on page 2. Ideally, the instructor should lead students through each step and make sure everyone has completed it successfully before continuing to the next step.

## Options:

1. Fill the box with written wishes, promises, thoughts, poems or prayers.

## Materials

**2-Ply Tag Board**, size 9" x 12" (13111-1003), white, 100-sheet package cut to 9" x 9" or 6" x 6" squares, need one square per student

**Armada Lollypop Scissors** (57057-1007), need one per student

**3M Scotch® #810 Magic™ Transparent Tape** (23012-0050), share five rolls across class

Colored Pencils, recommend:

**Faber-Castell Red-Line Colored Pencils**, set of 24 colors (20553-1024), share five sets across the class

**Faber-Castell Red-Line Metallic Pencils** set of 12 colors (20552-1012), share five sets across the class

Gel Pens, recommend:

**Sakura Gelly Roll® Pen 5-Pen Sets**, metallic (20747-0059) or assorted colors (20747-1159), share four sets across class

**Blick Aluminum Rulers**, 18" (55430-1018), one per student

**Blick White Sulphite Drawing Paper**, 50-lb 9" x 12", (10209-1013), 500 sheet ream, need at least one sheet per student

## How to make an Origami Box:

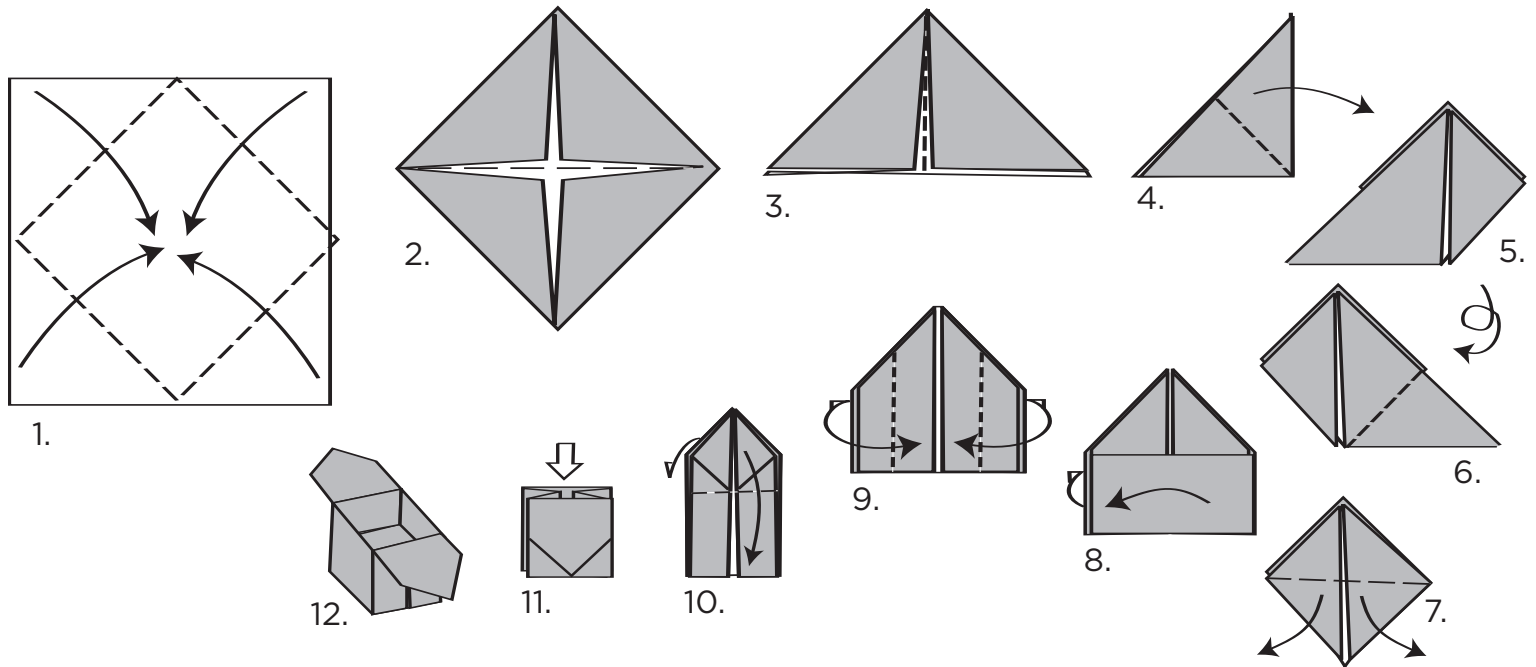

### National Standards

Content Standard #1 – Understanding and applying media, techniques, and processes

**K-4** Students use different media, techniques, and processes to communicate ideas, experiences, and stories

**5-8** Students select media, techniques, and processes; analyze what makes them effective or not effective in communicating ideas; and reflect upon the effectiveness of their choices

Content Standard #4 – Understanding the visual arts in relation to history and cultures

**K-4** Students identify specific works of art as belonging to particular cultures, times, and places

**5-8** Students describe and place a variety of art objects in historical and cultural contexts